



## Switch track, electric Technical specifications

### Function

Max capacity	: 275 kg
Usage	: When it is necessary to divide a single track rail into 2 tracks in a Guldmann rail system
Connecting rail	: Rail A
Operation	
Electric	: Hand control

### Weight and materials

Switch track 90°	: 10,4 kg
Switch track railpart	: Anodized aluminium
Plateparts	: Stainless steel

### Measurements

A.	: 551 mm
B.	: 50 mm
C.	: 62 mm
D.	: 900 mm
E.	: 550 mm

### Safety

Electric	: Electronically secured
----------	--------------------------

### Electrical parts

On/off	: Automatically on activation
Motor consumption	: 24V DC5W
Periodic load	: 10/90
Power supply	: 33V AC, 2.5A
Supply voltage transformer	: 115/230 V AC

### Classification, tightness

Hand control	: IP 54
--------------	---------

### Accessories/ Miscellaneous

Infrared IR remote control	
Receiver	: To be mounted externally with plug
Sender	: Hand switch with batteries
Range	: 5-10 metres
Diffusion	: approx. 30 degrees
Hand control	: With cable
Wall switch	: Wall integrated
Power supply	: Transformer

### Service and guarantee

Service check	: At the same time as the hoist
Guarantee	: 1 year

### Marking

The product is manufactured in compliance with regulation (EU) 2017/745 of the European parliament and of the Council of 5 April 2017, as medical device Class I.

### Item Number/Model

553925	: Switch track, electric 90° right
553926	: Switch track, electric 90° left

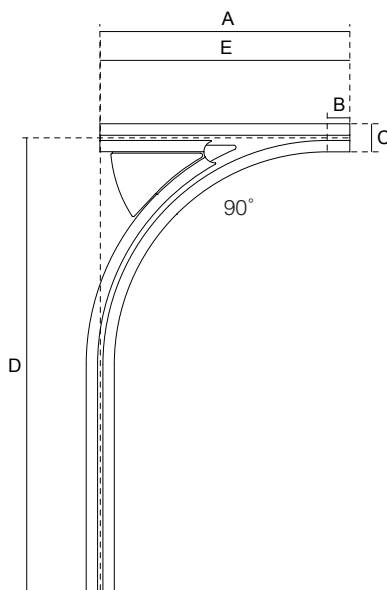

Time to care