

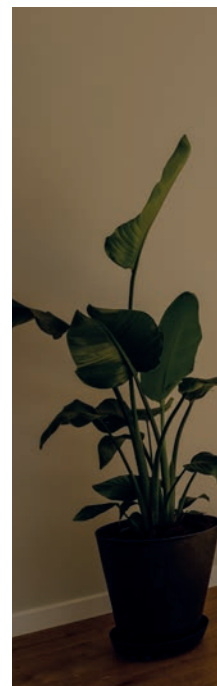

Platform lifts
LP50 & LP50H



DISCREET AND AESTHETIC SOLUTION

Both the LP50 and LP50H provide a very simple and discreet solution that is almost invisible when not in use. These lifting platforms are customized to blend seamlessly with the surroundings, becoming a natural part of the building or room. The LP50 and LP50H are particularly suitable for heritage buildings or places where an aesthetic solution is required.

Customization to the actual building or specific interior design is possible since the lifting platforms are designed to accommodate for 22 mm flooring, such as wood, tiles, carpets, or similar materials. Both lifting platforms have a very low installation height of 160 mm, making it extremely easy to install the platform without the need for significant structural modifications.



THE DIFFERENCE IS IN THE DETAIL

The Stepless LP50 and LP50H are indoor floor-mounted lifting platforms designed to assist people with reduced mobility when negotiating small level differences. The platforms are integrated into the floor in front of the staircase to be negotiated. Both platforms can lift up to 830 mm and have a lifting capacity of 375 kg.



- ▲ **LP50** – with no upper landing gate. This version lifts vertically up to 830 mm.
- ◀◀ **LP50H** – lifts vertically up to 830 mm with horizontal travel of the platform up to 900 mm. This means that the lifting platform moves over the staircase without interfering with the staircase or the surrounding space.



Heritage Buildings



Public Buildings



Private Homes

EASY TO OPERATE

The LP50 and LP50H features a user-friendly and intuitive operating panel ensuring that the most users can operate it independently.

SAFETY IS TOP PRIORITY

When activated, the LP50 and LP50H are equipped with safety edges that automatically run up all sides of the lifting platform. This prevents the user from driving off the edge of the platform while it is in use. When reaching the top level, the front edge of the platform automatically lowers to floor level – allowing the user to exit the platform easily and unhindered.

As an additional safety precaution to prevent foreign objects from entering, the LP50 and LP50H come with safety shields that cover and protect the entire lifting area of the platform.

It is important to note that regulations regarding lifting height and shielding may vary depending on local and national conditions.





WE GUIDE YOU – STEP BY STEP

If you require recommendations for a specific project, we can inspect the installation site and provide you with expert advice on the best solution. The installation itself is carried out by skilled installers, and since the LP50 and LP50H do not require significant structural modifications, the process is relatively easy and quick.

While the LP50 and LP50 H require minimal maintenance due to their simple and robust technology, it is crucial to regularly service the platform lifts. We recommend that you establish a service agreement either directly with Stepless by Guldmann or with a certified Stepless dealer.

◀ **LP50H** - with operation panel placed on the wall.



◀◀◀ *Optional platform covering – wood, tiles, carpet or other.*

◀◀ **LP50** - Very low installation height of only 160 mm.
Safety ramp along all sides.
Safety shields guarding the full lifting area.

◀ *User-friendly operating panel available in several different types to mount either on the wall, floor or directly on the lifting platform.*

TECHNICAL SPECIFICATIONS

LP50

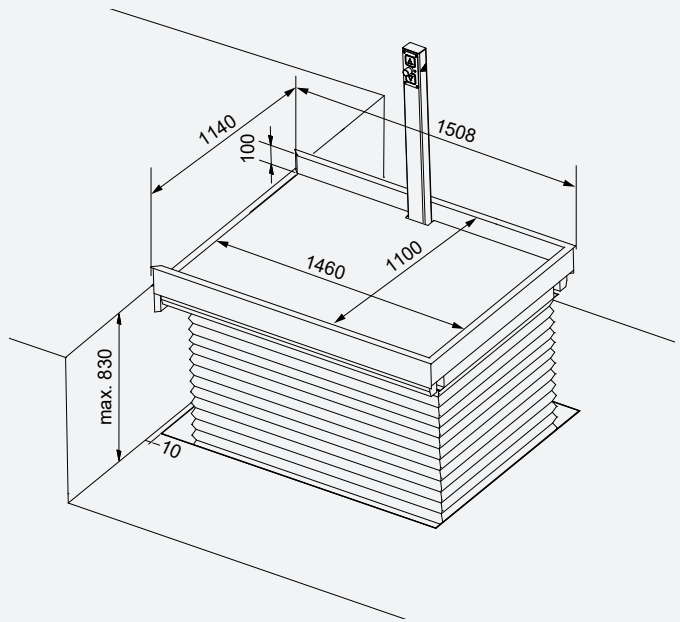
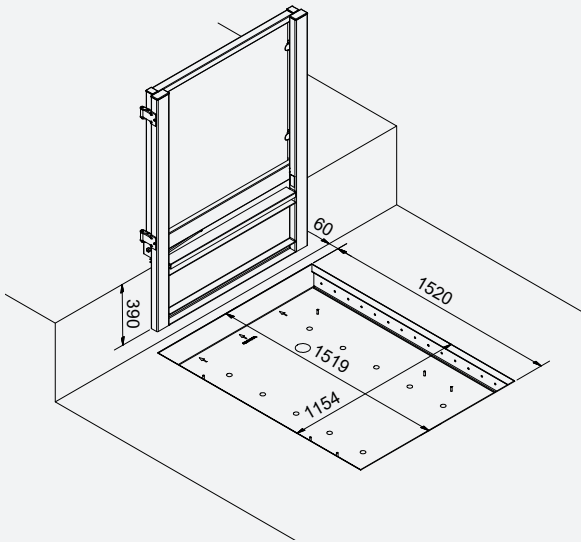

LP50H

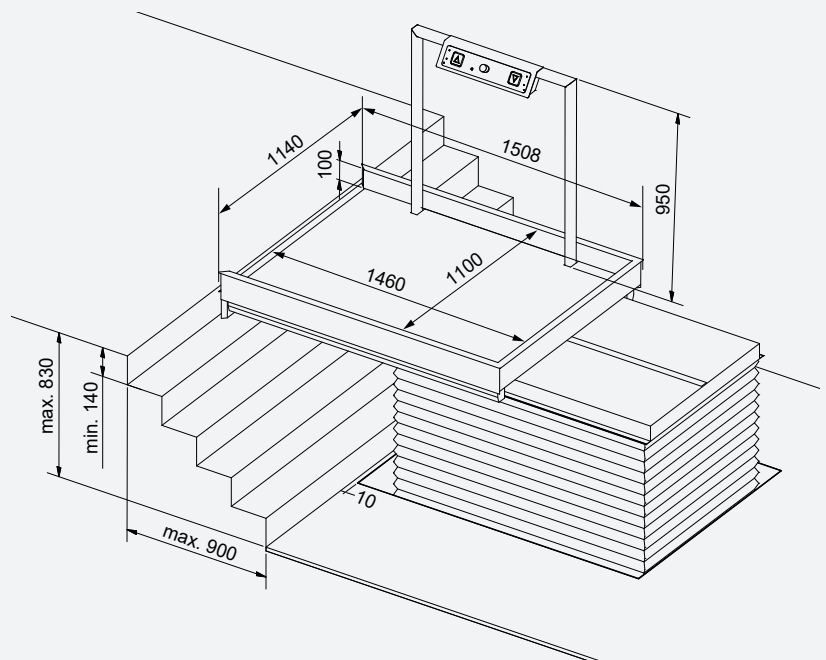
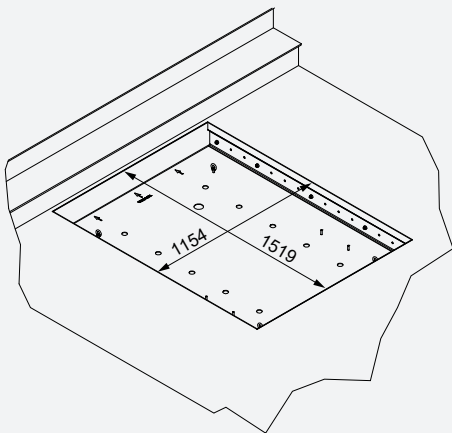

	LP50	LP50H
Functions		
Lifting capacity	375 kg	
Lifting speed	13 mm/sec	
Operation		
Electric	Operating panel/wireless operation	
Emergency stop	Electronic	
Safety cutout	Mechanical / electrical safety cutout	
Intended use	Indoor	
Weight		
LP50 / LP50H, incl. pallet	270 kg	310 kg
Frame, incl. pallet	210 kg	
Materials		
Materials	Aluminium / galvanized steel	
Safety edge	Anodized aluminium with rubber strip	
Operating panel	Powder coated steel. Front rustproof steel	
RAL Colour codes		
Stand alone panel	Stainless steel, RAL7016	
Platform floor finish	Optional	
Measurements		
Thickness of floor finish	22 mm	
Lifting height	830 mm. Be aware of local regulations in relation to lifting height.	
Pit depth	160 mm. Frame for embedment must always be supplied by Guldmann.	
Cantilever LP50H	-	900 mm
Electrical parts		
On/off	Automatically	
Power consumption		
Standby	16 W	
Standby (sleep mode)	10 W	
Operation	625 W	
Periodic load	10/90	
Fuse		
230 V fuse	4A mcb	
24 V fuse	20A mcb	
110 V fuse	6A mcb	
Batteries	2 x 12 V/4.5 Ah Gastight and maintenance-free	
Power supply		
Primary	90-264 Vac	
Secondary	24 Vdc	
Accessories		
	<ul style="list-style-type: none"> - External operating panel - Wireless operation - 2 way Communication 	

	LP50	LP50H
Marking		
	The product is manufactured in compliance with the Council Directive 2006/42/EC of May 17th 2006.	
Item Number/Model		
13013-xxx	LP50 vertical lifting platform	
13012-xxx		LP50H cantilever vertical lifting platform
1301211	Pit Frame for embedment with reinforcement	
Classification		
According to ISO 9999	18 30 06	

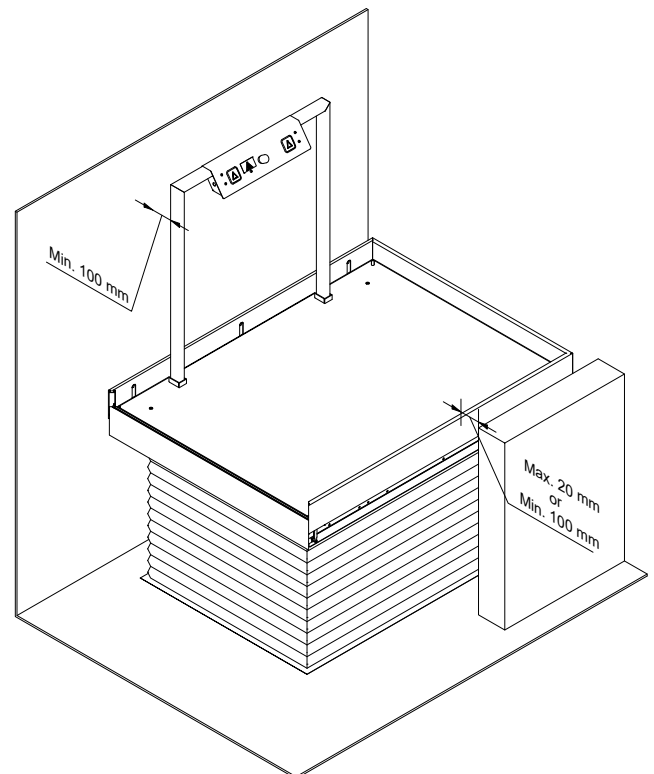

The platform is to be set up with a minimum distance of 100 mm from handrail to wall to avoid danger of crushing.



LP50H platform lift