



Guldmann Inc.
 Tel. 800 664 8834
 Tel. 813 880 0619
 info@guldmann.net
 www.guldmann.net

GH3 Twin Lifting module Technical specifications

Weight and materials

SWL	: 550 lbs, 825 lbs, 1100 lbs
Own weight	: 42.2 lbs

Covers : Impact-resistant UL 94 V-0 flame retardant recyclable plastic

Dimensions

A	: 860 mm (33 3/4")
B	: 817 mm (32")
C	: 156 mm (6 1/8")
D	: 184 mm (7 1/4")
E, min	: 655 mm (25 3/4")
F, max	: 3155 mm (123 3/4")
G	: 473 mm (18 1/2")
Depth of hoist	: 205 mm (8")

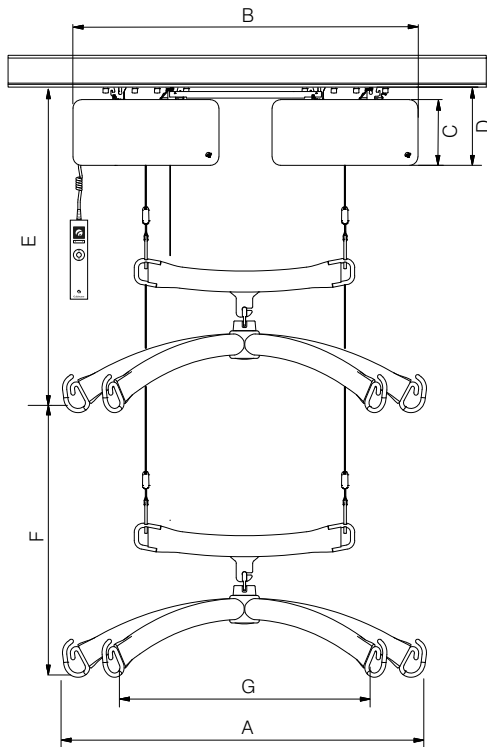

Functions

Operation	: Hand control / IR
Sound level	: 52 dB (A)

Safety

Emergency stop	: Yes
Emergency lowering device	: Yes, mechanical and electrical
Control of lifting strap	: Yes
Cut-off angle	: 45° along the rail 10° across the rail

Electronics

On/off	: Automatic when used. Soft start/stop. Overload protection.
Batteri	: 24 V NiMH, 2 x 2.1 Ah
Opladningstid, max.	: 4 timer

Battery protection : At battery voltage below 22 V the indicator light turns orange. The hoist is stopped if the voltage falls below 20 V

Power supply	: 33 V AC, 2.5 A
Supply voltage, transformer Class I	: 100-240V AC
transformer Class II	: 100-115V AC / 220-230V AC

Protection classification (IP) according to IEC 60529

Lifting module	: IP 20
Hand control	: IP 44
Remote control	: IP 20
Transformer Class I	: IP 20
Transformer Class II	: IP 21

Labelling

The product is manufactured in compliance with regulation (EU) 2017/745 of the European parliament and of the Council of 5 April 2017, as medical device Class I.

Classification

Pursuant to ISO 9999

Patents	: PA 2008 00888 PA 2008 00894 PA 2008 00895
---------	---

Time to care



Guldmann Inc.
 Tel. 800 664 8834
 Tel. 813 880 0619
 info@guldmann.net
 www.guldmann.net

GH3 Twin Lifting module Technical specifications

GH Lifting modules, configurations			Options													
Guldmann hoist type	Lifting speed, mm/s (Normal / Turbo)	Load in kg	Wi-Fi enabled	Data transmission shown on MyGuldmann	Hand control with display	Function on demand	Scale	Class III scale	Trainer	Coating	UL	Automatic charging	Charging in docking station	Positioning lock	IR remote ^{x)}	Horizontal drive motors ^{x)}
GH3+ Twin	60/100	250	✓	✓	✓	•	•	•		•	•	✓				
		375	✓	✓	✓	•	•			•	•	✓				
		500	✓	✓	✓	•	•	•		•	•	✓				

- *Optional*
- ✓ *Always included*
- x) *Not compatible with UL*

GH3 Twin	
Lifting speed	
185 lbs load	60 mm/sec.
330 lbs load	60 mm/sec.
Max capacity load, SWL	55 mm/sec.
Max 11 lbs load	60/100 mm/sec.

Number of lift and Intermittent

Max. number of lift in series: 55 with 185 lbs/40"
 Charging time : 4 hours
 Intermittent : 2 min. ON/18 min. OFF

Max. number of lift in series: 21 with 550 lbs/40"
 Charging time : 4 hours
 Intermittent : 2 min. ON/18 min. OFF

Max. number of lift in series: 21 with 825 lbs/40"
 Charging time : 4 hours
 Intermittent : 2 min. ON/18 min. OFF

Max. number of lift in series: 21 with 1100 lbs/40"
 Charging time : 4 hours
 Intermittent : 2 min. ON/18 min. OFF